

SOLAR PANEL COOLING AND CLEANING SYSTEM

RAJAM HARTHI ¹, EMANDI SANDEEP ², CHALAPAREDDI RAMAKRISHNA ³, KATTA MANOJ KUMAR ⁴, Mr. V. SARATH KUMAR ⁵

¹ Student, Department of Electrical and Electronics Engineering, Satya Institute of Technology and Management, Vizianagaram, Andhra Pradesh, India. rajamharathi234@gmail.com

² Student, Department of Electrical and Electronics Engineering, Satya Institute of Technology and Management, Vizianagaram, Andhra Pradesh, India emandisandeep7@gmail.com

³ Student, Department of Electrical and Electronics Engineering, Satya Institute of Technology and Management, Vizianagaram, Andhra Pradesh, India. chalapareddyramakrishna@gmail.com

⁴ Student, Department of Electrical and Electronics Engineering, Satya Institute of Technology and Management, Vizianagaram, Andhra Pradesh, India. kattamanojkumar196@gmail.com

⁵ Professor, Department of Electrical and Electronics Engineering, Satya Institute of Technology and Management, Vizianagaram, Andhra Pradesh, India. volluru@gmail.com

ABSTRACT

Solar panels are widely used for generating renewable energy, but their efficiency can be significantly reduced due to the accumulation of dust, dirt, and environmental factors such as high temperature. Dust particles deposited on the surface of solar panels block sunlight and decrease the amount of energy generated. Regular cleaning of solar panels is therefore necessary to maintain optimal performance. However, manual cleaning is time-consuming and requires continuous monitoring. To overcome these challenges, a solar panel cleaning and monitoring system is developed using an Arduino-based automation approach. The system integrates sensors such as an LDR sensor to measure light intensity, a voltage sensor to monitor the output voltage of the solar panel, and a DHT11 sensor to measure temperature conditions. The collected data is displayed on an LCD screen to provide real-time monitoring of the system parameters.

The proposed system continuously analyzes the light intensity and the voltage generated by the solar panel. If the LDR detects high light intensity but the generated voltage is low, the system identifies the presence of dust on the solar panel surface. In such a situation, the cleaning mechanism is automatically activated. The cleaning process includes water sprinkling and a brush movement mechanism driven by DC motors controlled through an L298 motor driver. The brush moves forward until it reaches a limit

switch and then returns to its initial position using another limit switch. Additionally, if the temperature detected by the DHT11 sensor becomes excessively high, the cleaning mechanism is also activated to help cool the panel surface. This automated system helps maintain solar panel efficiency by ensuring regular cleaning and continuous performance monitoring.

Keywords: *Solar Energy, Solar Panel Cleaning, Arduino Uno, LDR Sensor, DHT11 Sensor, Automated Cleaning System, Renewable Energy, Smart Monitoring System.*

INTRODUCTION

Solar energy is one of the most important renewable energy sources used for electricity generation due to the increasing demand for energy and the depletion of fossil fuels. Solar panels convert sunlight into electrical energy using photovoltaic (PV) cells. Solar energy is clean, environmentally friendly, and available in abundant quantity. Because of these advantages, solar panels are widely used in residential, commercial, and industrial applications. However, the efficiency of solar panels depends on environmental conditions such as sunlight intensity, temperature, and cleanliness of the panel surface. Dust accumulation, bird droppings, and other particles on the surface of solar panels reduce the amount of sunlight reaching the photovoltaic cells, which decreases the power output of the solar panel.

In many areas, especially dusty regions, solar panels lose a significant amount of efficiency due to dust accumulation. Studies show that dust can reduce solar

panel efficiency by 10% to 25% if panels are not cleaned regularly. Manual cleaning of solar panels is time-consuming, requires human effort, and is not practical for large-scale solar installations or panels installed on rooftops. In addition to dust, high temperature is another major factor that affects solar panel performance. When the temperature of the solar panel increases, the voltage output decreases, which reduces the overall efficiency of the system. Therefore, both cleaning and cooling of solar panels are necessary to maintain their efficiency and performance. To overcome these problems, an automated solar panel cleaning and cooling system is proposed. The system uses sensors such as an LDR sensor to measure light intensity, a voltage sensor to measure the output voltage of the solar panel, and a DHT11 sensor to measure temperature. These sensors continuously monitor the condition of the solar panel. The system uses an Arduino microcontroller as the main control unit to process the sensor data and make decisions. If the system detects dust on the panel surface or high temperature, it automatically activates the cleaning and cooling mechanism.

The cleaning system consists of a water pump and a rotating brush driven by DC motors. The brush moves across the solar panel surface to remove dust and dirt, while the water pump sprays water to clean and cool the panel. Limit switches are used to control the movement of the cleaning mechanism. An LCD display is used to display system parameters such as temperature, voltage, and system status. This automated system reduces manual work, improves solar panel efficiency, and ensures continuous monitoring and maintenance of the solar panel.

The main objective of this project is to design and develop an automated system that can monitor solar panel performance, detect dust accumulation, and automatically clean and cool the solar panel to maintain maximum efficiency. This system helps in improving energy generation, reducing maintenance cost, and increasing the lifespan of the solar panel. The proposed system is cost-effective, reliable, and suitable for both small-scale and large-scale solar power applications.

1.1 Problem Statement

Solar energy systems are widely used for electricity generation, but their efficiency is greatly affected by environmental factors such as dust accumulation, dirt, bird droppings, and high temperature. Dust particles deposited on the surface of solar panels block sunlight

from reaching the photovoltaic cells, which reduces the electrical power output. Over time, this leads to significant energy loss and reduced efficiency of the solar power system. In many installations, solar panels are cleaned manually, which requires human effort, time, and regular maintenance. Manual cleaning is not efficient for large solar farms, rooftop installations, or panels installed in remote areas.

Another major problem is the increase in temperature of solar panels due to continuous exposure to sunlight. High temperature reduces the voltage output and overall efficiency of photovoltaic cells. Without proper cooling and monitoring systems, solar panels may operate below their maximum efficiency level. In most traditional solar systems, there is no automatic monitoring system to detect dust accumulation or temperature rise. As a result, cleaning is not performed at the right time, leading to reduced performance and energy loss.

Therefore, there is a need to develop an automated system that can continuously monitor solar panel conditions such as light intensity, voltage output, and temperature, and automatically activate cleaning and cooling mechanisms when required. The system should reduce manual work, improve efficiency, and ensure proper maintenance of solar panels.

1.2 Scope of Research

The scope of this research focuses on the design and development of an automated solar panel cleaning and cooling system using an Arduino microcontroller. The research mainly concentrates on monitoring important parameters such as light intensity, solar panel voltage, and temperature using sensors like LDR, voltage sensor, and DHT11 sensor. Based on the sensor data, the system automatically detects dust accumulation or high temperature and activates the cleaning and cooling mechanism.

The research includes the design of an automated cleaning mechanism using DC motors, a rotating brush, and a water pump controlled through a motor driver. Limit switches are used to control the movement of the cleaning mechanism to ensure safe operation. The system also includes an LCD display to show real-time sensor values such as temperature, voltage, and system status.

This research is limited to small-scale solar panel systems and focuses mainly on improving solar panel efficiency through automatic cleaning and cooling. The project does not focus on large-scale industrial solar tracking systems but aims to develop a cost-

effective and efficient automated maintenance system for solar panels. The system can be used in residential solar systems, small industries, agricultural applications, and solar farms. The main scope of this research is to improve solar panel performance, reduce maintenance work, and increase the overall efficiency and lifespan of solar panels using automation technology.

2. LITERATURE SURVEY

Solar energy is one of the most widely used renewable energy sources for electricity generation. However, the efficiency of solar panels is affected by environmental factors such as dust accumulation, temperature rise, shading, and lack of maintenance. Dust particles on the surface of solar panels reduce the amount of sunlight reaching the photovoltaic cells, which decreases the power output. Similarly, high temperature reduces the voltage output of solar panels and affects overall system performance. To overcome these problems, many researchers have developed automatic solar panel cleaning systems, cooling systems, and monitoring systems using sensors, microcontrollers, and robotic mechanisms. This chapter presents the literature review of various research works related to solar panel cleaning, cooling, and monitoring systems.

Shasoto Biswas et al. (2023) developed an IoT-based automated solar panel cleaning and monitoring system to improve the efficiency of photovoltaic panels. The system used sensors, a microcontroller, and a wireless communication system to monitor solar panel performance and automatically activate cleaning when dust was detected. The study concluded that automated cleaning significantly improves solar panel efficiency and reduces manual maintenance.

Anjali Roy et al. (2024) designed an automatic solar panel cleaning robot with wireless monitoring capabilities. The system used DC motors, brushes, and sensors to remove dust from the solar panel surface. The research showed that robotic cleaning systems are effective for large solar installations and reduce human effort.

Dnyaneshwar G. Kanade et al. (2024) proposed a solar panel cleaning system based on LDR and voltage sensor comparison. The system detects dust by comparing sunlight intensity with the voltage output of the panel. If light intensity is high and voltage is low, the system identifies dust accumulation and activates the cleaning mechanism.

This method was found to be simple and cost-effective.

Rakshith K. et al. (2025) developed a smart automated solar panel cleaning robot using Arduino and motor driver circuits. The system used a brush mechanism and water pump for cleaning solar panels. The research showed that automatic cleaning systems can maintain panel efficiency and reduce maintenance cost.

Indra Kishor et al. (2025) proposed an AI-based solar panel cleaning and predictive maintenance system. The system used machine learning algorithms to predict dust accumulation and system faults. The study concluded that AI-based maintenance systems can improve solar panel performance and reduce energy loss.

S. K. Singh and P. Kumar (2022) studied the effect of dust on solar panel performance and found that dust accumulation can reduce efficiency by 10% to 25%. The study recommended regular cleaning to maintain efficiency.

M. A. Ahmed (2023) developed an automated solar panel cleaning system using Arduino and water spray mechanism. The system automatically cleaned the solar panel when dust was detected. The research showed that automated cleaning improves energy output.

H. Patel and D. Shah (2022) developed an IoT-based solar monitoring system that monitors voltage, current, and temperature of solar panels and sends data to the cloud for remote monitoring.

L. Chen and Y. Wang (2021) designed a robotic cleaning mechanism for solar panels using motorized brush and water spray system. The system improved solar panel efficiency and reduced manual cleaning effort.

FAO Report (2022) explained the importance of maintenance and cleaning in solar photovoltaic systems and concluded that regular cleaning and cooling can significantly improve solar panel efficiency and lifespan.

3. EXISTING SYSTEM

In the existing system, solar panels are generally cleaned manually to remove dust, dirt, and other particles that accumulate on the panel surface. Manual cleaning methods include using water, cloth, or brushes to clean the solar panels at regular intervals. In some solar power plants, workers are

employed to clean the panels periodically. However, manual cleaning requires human effort, time, and regular monitoring. In many cases, cleaning is not performed at the correct time because there is no proper monitoring system to detect dust accumulation. As a result, dust remains on the panel surface for a long time, which reduces the efficiency of the solar panel. Some existing systems use basic monitoring systems that only measure voltage and current but do not automatically clean the panel. Other systems use robotic cleaning mechanisms, but they are expensive and complex to implement. Most of the existing systems do not include both cleaning and cooling mechanisms together, and many systems lack automation and real-time monitoring features.

Disadvantages of Existing System

The main disadvantage of the existing system is that manual cleaning requires human labor and regular maintenance, which increases operational cost and time. Another disadvantage is that dust accumulation is not detected automatically, so cleaning may not be done at the right time, leading to reduced solar panel efficiency. High temperature is another factor that affects solar panel performance, but many existing systems do not include a cooling mechanism to reduce panel temperature. Some automated cleaning systems are available, but they are expensive and complicated, making them unsuitable for small-scale applications. In addition, many existing systems do not have real-time monitoring systems to monitor solar panel performance parameters such as voltage, temperature, and light intensity. Due to these limitations, existing systems are less efficient, require more maintenance, and may result in energy loss. Therefore, an automated solar panel cleaning and cooling system is required to improve efficiency, reduce manual work, and maintain solar panel performance.

4. PROPOSED SYSTEM

The proposed system is an automated solar panel cleaning and cooling system designed to improve the efficiency and performance of solar panels by removing dust and reducing panel temperature. In this system, sensors are used to continuously monitor the condition of the solar panel, and based on the sensor readings, the system automatically activates the cleaning and cooling mechanism. The main components used in this system include a solar panel, Arduino microcontroller, LDR sensor, voltage sensor, DHT11 temperature sensor, motor driver, DC

motor, water pump, limit switches, battery, and LCD display.

The solar panel generates electrical energy from sunlight and supplies power to the battery through a charge controller. The battery provides power to the Arduino and other components in the system. The Arduino acts as the main control unit of the system. It continuously receives input data from the LDR sensor, voltage sensor, and temperature sensor. The LDR sensor is used to measure the intensity of sunlight falling on the solar panel. The voltage sensor is used to measure the output voltage of the solar panel. The DHT11 sensor is used to measure the temperature around the solar panel.

The Arduino continuously compares the light intensity value with the voltage output of the solar panel. Under normal conditions, when sunlight intensity is high, the solar panel should produce a high voltage. If the LDR sensor detects high light intensity but the voltage output is low, it indicates that dust has accumulated on the surface of the solar panel. In this condition, the Arduino activates the cleaning mechanism automatically. The cleaning mechanism consists of a water pump and a rotating brush driven by a DC motor. The water pump sprays water on the solar panel surface to loosen dust and dirt particles, and the rotating brush cleans the panel surface.

The movement of the brush is controlled using limit switches placed at both ends of the solar panel. When the brush reaches the end of the panel, the limit switch sends a signal to the Arduino to stop the motor and reverse the direction of the motor so that the brush returns to its initial position. This ensures automatic cleaning of the entire panel surface without human intervention.

The system also includes a cooling mechanism. When the temperature sensor detects that the temperature of the solar panel exceeds a certain threshold value, the Arduino activates the water pump to spray water on the panel surface to reduce the temperature. This helps in maintaining the efficiency of the solar panel because high temperature reduces the voltage output of photovoltaic cells.

An LCD display is used to display system parameters such as temperature, voltage, light intensity, and system status. The entire system works automatically and ensures that the solar panel is cleaned and cooled whenever required. This improves solar panel efficiency, reduces manual work, and increases the lifespan of the solar panel. The proposed system is

cost-effective, efficient, and suitable for small-scale and medium-scale solar power applications.

4.1 Block Diagram

The block diagram of the automated solar panel cleaning and cooling system represents the overall working flow of the system. The main blocks in the system are the solar panel, charge controller, battery, Arduino microcontroller, sensors (LDR, voltage sensor, temperature sensor), motor driver, DC motor, water pump, limit switches, and LCD display.

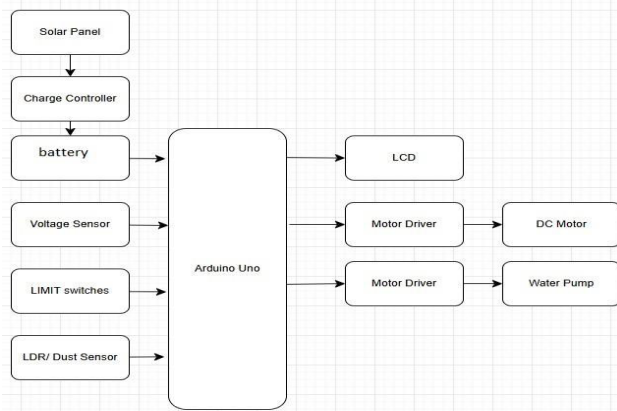

Fig. 1: Block Diagram

4.2 Block Diagram Description

The solar panel converts sunlight into electrical energy using the photovoltaic effect. The generated electrical energy is regulated using a charge controller and stored in a rechargeable battery. The battery supplies power to the Arduino microcontroller, sensors, motor driver, LCD display, DC motor, and water pump.

The Arduino microcontroller acts as the central control unit of the system. It receives input signals from the LDR sensor, voltage sensor, temperature sensor, and limit switches. The LDR sensor measures the light intensity falling on the solar panel. The voltage sensor measures the output voltage of the solar panel. The temperature sensor measures the temperature around the solar panel. These sensor values are continuously monitored by the Arduino.

The Arduino compares the LDR sensor value and voltage sensor value to detect dust on the solar panel. If the light intensity is high and the voltage output is low, the system detects dust accumulation and activates the cleaning mechanism. The Arduino sends control signals to the motor driver, which drives the DC motor. The DC motor moves the cleaning brush across the solar panel surface. At the same time, the

Arduino activates the relay to turn on the water pump, which sprays water on the panel for cleaning.

Limit switches are placed at both ends of the solar panel to detect the position of the cleaning mechanism. When the cleaning brush reaches the end of the panel, the limit switch sends a signal to the Arduino, which stops the motor and reverses the direction of the motor to bring the brush back to its original position. This ensures automatic and safe operation of the cleaning mechanism.

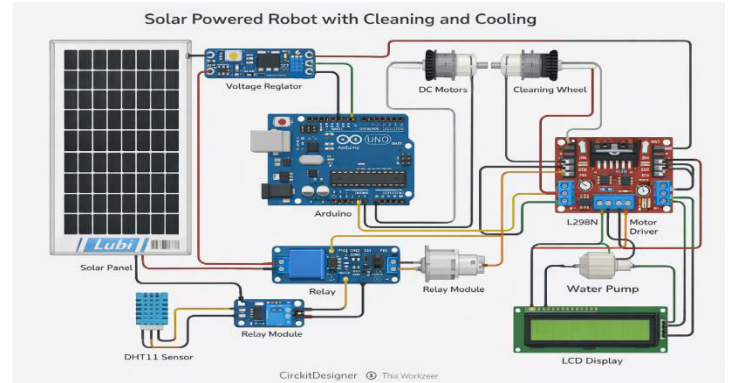

Fig 2: Circuit Diagram

If the temperature sensor detects high temperature, the Arduino activates the water pump to spray water for cooling the solar panel. This reduces the temperature and improves the efficiency of the solar panel.

The LCD display is connected to the Arduino to display system parameters such as temperature, voltage, light intensity, and system status. The block diagram shows the complete flow of energy and control signals in the system. Thus, the system automatically monitors, cleans, and cools the solar panel to maintain maximum efficiency and performance.

5. RESULTS

The automated solar panel cleaning and cooling system was successfully designed and implemented. The system was tested under different environmental conditions to observe its performance. During the testing process, the system continuously monitored light intensity, solar panel voltage, and temperature using the LDR sensor, voltage sensor, and DHT11 temperature sensor. The sensor values were displayed on the LCD display in real time, which helped in monitoring the performance of the solar panel.

Initially, dust was allowed to accumulate on the solar panel surface, and the system readings were observed. It was found that when dust accumulated on the solar

panel, the voltage output of the panel decreased even though the light intensity was high. The system successfully detected this condition by comparing the LDR value and voltage value. When the system detected dust on the panel surface, the Arduino activated the cleaning mechanism automatically. The water pump started spraying water, and the DC motor moved the brush across the surface of the solar panel. After cleaning, the voltage output of the solar panel increased, which showed that the cleaning system improved the efficiency of the solar panel.

5.1 Hardware Setup

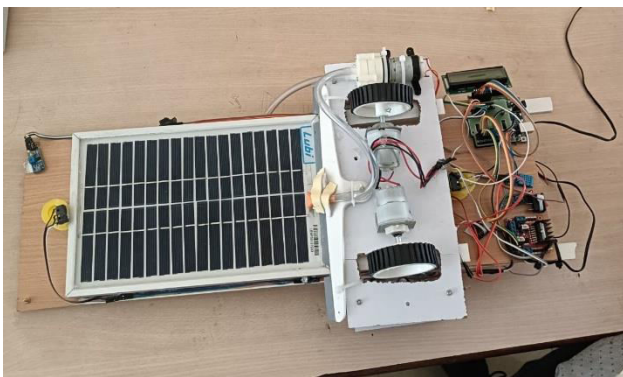

Fig. 3: Prototype

The system was also tested for high temperature conditions. When the temperature sensor detected a temperature above the preset limit, the system activated the water pump to spray water on the solar panel for cooling. After cooling, the temperature of the solar panel decreased, and the voltage output improved. This shows that cooling helps in maintaining the efficiency of the solar panel.

The limit switches successfully controlled the movement of the cleaning brush by stopping the motor at the end position and reversing the motor direction to return the brush to its initial position. The entire cleaning process was completed automatically without human intervention.

Overall, the system successfully performed automatic monitoring, cleaning, and cooling operations. The results show that the automated cleaning and cooling system improves solar panel efficiency, reduces manual work, and ensures proper maintenance of the solar panel system. The system is reliable, efficient, and

suitable for real-time solar panel maintenance applications.

6. CONCLUSION

In this project, an automated solar panel cleaning and cooling system using Arduino was successfully designed and implemented to improve the efficiency and performance of solar panels. The system continuously monitors important parameters such as light intensity, solar panel voltage, and temperature using LDR, voltage sensor, and DHT11 sensor. Based on the sensor data, the Arduino microcontroller automatically detects dust accumulation and high temperature conditions and activates the cleaning and cooling mechanism.

The cleaning system consists of a water pump and a rotating brush driven by a DC motor, which removes dust and dirt from the surface of the solar panel. The cooling system uses water sprinkling to reduce the temperature of the solar panel when it exceeds a certain limit. Limit switches are used to control the movement of the cleaning mechanism and ensure safe operation. The LCD display shows real-time values such as temperature, voltage, and system status, which helps in monitoring the system performance.

The results show that dust accumulation reduces the voltage output of the solar panel, and after cleaning, the voltage output increases, which improves the efficiency of the solar panel. Similarly, cooling the panel helps in reducing temperature and maintaining panel efficiency. The automated system reduces manual work, saves time, and ensures regular maintenance of solar panels.

Overall, the proposed system is cost-effective, reliable, and efficient for maintaining solar panel performance. This system can be used in residential solar systems, solar farms, and remote areas to improve energy generation and increase the lifespan of solar panels. The project demonstrates the effective use of automation in renewable energy systems for improving efficiency and performance.

References.

- [1] Shasoto Biswas, Md. R. Islam, and M. A. Rahman, "IoT-Based Automated Solar Panel Cleaning and Monitoring System," *International Journal of Renewable Energy Research*, vol. 13, no. 2, pp. 1–8, 2023.
- [2] Anjali Roy, S. Chatterjee, and R. Dutta, "Automatic Solar Panel Cleaning Robot with Wireless Monitoring,"

Journal of Modern Agriculture Engineering, vol. 5, no. 3, pp. 45–52, 2024.

[3] Dnyaneshwar G. Kanade, P. R. Patil, and S. B. Patil, “Solar Panel Cleaning System Based on Voltage Drop Detection and LDR Sensing,” *International Journal of Engineering Research and Technology*, vol. 12, no. 4, pp. 210–215, 2024.

[4] Rakshith K., M. N. Kumar, and P. V. Reddy, “Smart Automated Solar Panel Cleaning Robot Using Arduino,” *International Journal of Innovative Technology and Exploring Engineering*, vol. 14, no. 1, pp. 120–125, 2025.

[5] Indra Kishor, A. Sharma, and R. Singh, “AI-Integrated Robotic System for Solar Panel Cleaning and Predictive Maintenance,” *Scientific Reports*, vol. 15, no. 2, pp. 1–10, 2025.

[6] S. K. Singh and P. Kumar, “Effect of Dust on Photovoltaic Panel Efficiency and Cleaning Methods,” *Renewable Energy Journal*, vol. 45, no. 6, pp. 230–236, 2022.

[7] M. A. Ahmed, “Automated Solar Panel Cleaning System Using Arduino,” *International Journal of Advanced Engineering Research*, vol. 10, no. 2, pp. 55–60, 2023.

[8] H. Patel and D. Shah, “IoT-Based Smart Monitoring System for Solar Energy Applications,” *Journal of Solar Energy Engineering*, vol. 9, no. 1, pp. 33–40, 2022.

[9] L. Chen and Y. Wang, “Design and Implementation of Robotic Cleaning Mechanism for Solar Panels,” *IEEE International Conference on Renewable Energy and Robotics*, pp. 150–155, 2021.

[10] Food and Agriculture Organization (FAO), “Maintenance and Efficiency Improvement in Solar Photovoltaic Systems,” FAO Technical Report, 2022.